

TOSHIBA MACHINE'S
HIGH SPEED SCARA ROBOT

TH650A

- HIGH LOAD CAPACITY ··· Maximum 10kg
- HIGH SPEED ··· Cycle time 0.31s
(With 2kg payload)
- POSITIONING REPEATABILITY
··· X,Y $\pm 0.01\text{mm}$, Z $\pm 0.01\text{mm}$, C $\pm 0.004\text{deg}$
- HIGH RIGIDITY
- BUILT-IN PLC ··· Ready for Touch-Sensitive
Operation panel
- DUCT-LESS DESIGN

Robot specifications



Model	TH650A	
Type	Horizontal Multi-joint	
Number of controlled axis	4	
Arm length	650mm (300mm+350mm)	
Working envelope	Axis 1	$\pm 160^\circ$
	Axis 2	$\pm 143^\circ$
	Axis 3(Z-axis)	200mm/400mm
	Axis 4(Z-axis rotation)	$\pm 360^\circ$
Maximum speed	Axis 1	340°/s
	Axis 2	600°/s
	Axis 3(Z-axis)	2050mm/s
	Axis 4(Z-axis rotation)	1700°/s
	Composite	7.52m/s
Standard cycle time(with 2kg payload)	0.31s	
Maximum payload mass	10kg	
Allowable moment of inertia at end	0.1kgm ²	
Positioning repeatability	X-Y(Plane)	$\pm 0.01\text{mm}$
	Z-axis (vertical)	$\pm 0.01\text{mm}$
	Axis 4(Z-axis rotation)	$\pm 0.004^\circ$
Input/output signals for hand	5 inputs / 4 outputs	
Air piping for hand	$\phi 6 \times 4$ pcs.	
Position detecting system	Absolute system	
Robot-controller cable	5m (Optional length maximum 25m)	
Mass	52kg	

Controller specifications



Model	TS2100
No. of axis	Maximum five-axis simultaneous control
Operation mode	PTP, CP (linear, circular), Short-cut, Arch motion
Storage capacity	Total: Approx 6400 points +12800 steps 1 program: Approx 2000point+3000steps
No. of programs	Max. 256 (247 user files + 9 system files)
Programming language	SCOL (proprietary, similar to BASIC)
Teaching unit	Teach pendant TP1000, with 5-meter cable (Program can be written on PC)
External inputs/outputs (general)	31+7 inputs / 22+10 outputs (7/10 can be switchable with system)
Hand control signals	5 inputs/4 outputs
External operation signals(exclusive)	Inputs: Cycle operation start, stop, reset, etc. Outputs: Servo-On status, emergency stop, ready for operation, malfunction alarm, etc.
Serial communication port	RS-232C: 2ports
Other functions	Torque control, Interruptive functions, self-diagnosis, I/O control and communications during motion, Coordinate calculations, etc.
Power supply	Three-phase AC190~250V 50/60Hz
Power capacity	3.5kVA
Outer dimensions and mass	420W×230H×300D(mm), 16kg
PC software (optional)	TSPC···Program editor, Teaching, remote operation, etc.
Options	I/O extension, field-network connection, Conveyor synchronization, etc.

TH650A External view

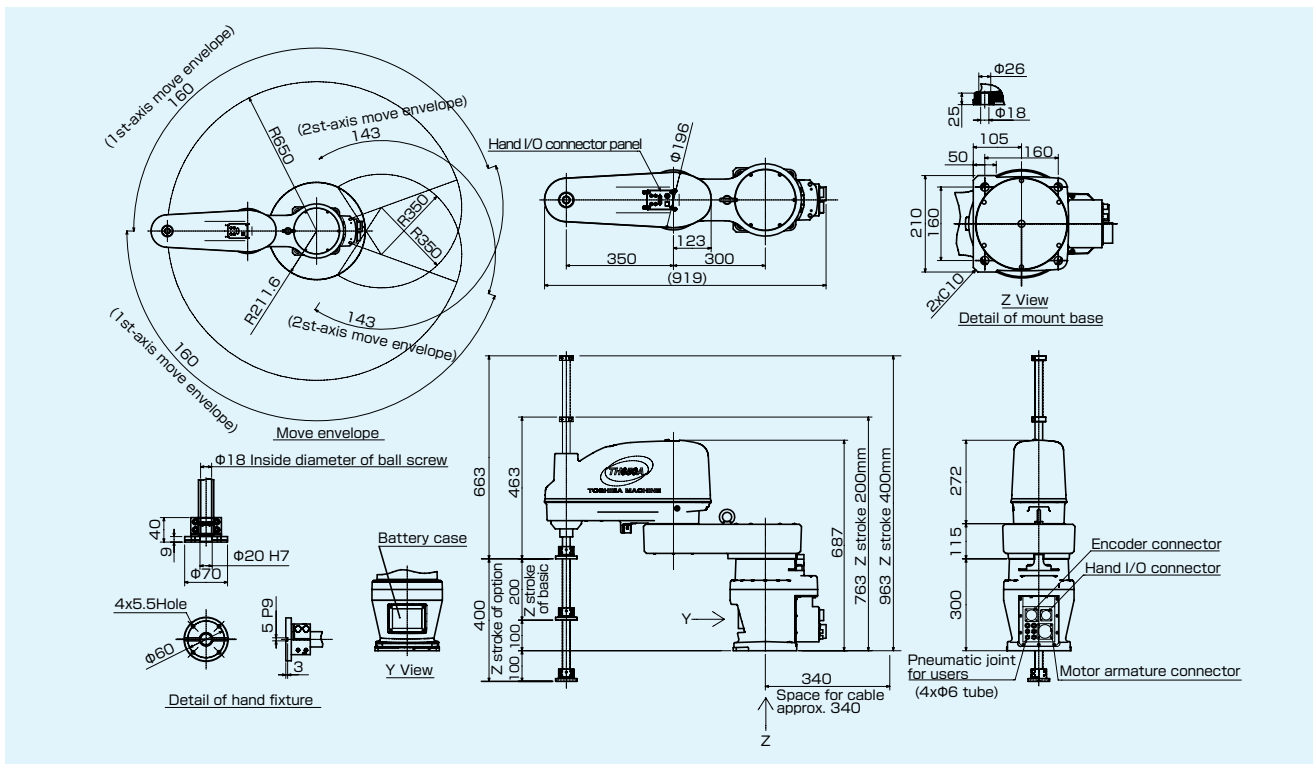

TS2100 External view

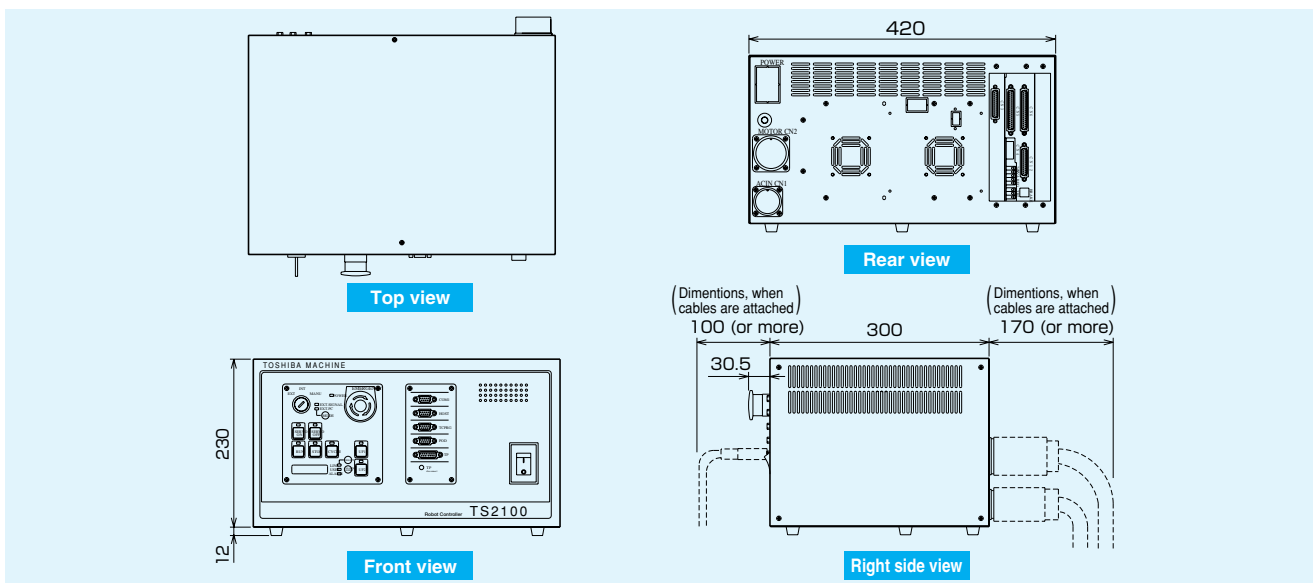

TOSHIBA MACHINE CO.,LTD. HEAD OFFICE
 Control Systems Sales Department, Control Systems Division
 2068-3, Ooka, Numazu-shi, Shizuoka-ken 410-8510, Japan
 TEL:[81]-(0)55-926-5032 FAX:[81]-(0)55-925-6527
 URL <http://www.toshiba-machine.co.jp/seiji/prod/sr>
 E-MAIL robot@toshiba-machine.co.jp

TOSHIBA MACHINE CO.,AMERICA.
 755 Greenleaf Avenue, Elk Grove Village, IL 60007, U.S.A.
 TEL:[1]-847-593-1616 FAX:[1]-847-593-0897
 URL http://www.toshiba-machine.com/robotics/SR_homepagef.htm
 E-MAIL salesleads@toshiba-machine.com

TM ROBOTICS(EUROPE) LTD.
 Unit 15, The Weltech Centre,
 Ridgeway Welwyn Garden City, Herts AL7 2AA UK
 TEL:[44]-(0)1707-871535 FAX:[44]-(0)1707-393959
 URL <http://www.tmrobotics.co.uk>
 E-MAIL info@tmrobotics.co.uk

URL http://www.toshiba-machine.co.jp/english/product/sr_e/