

SEALING

- SEMI OR FULLY AUTOMATIC
- UNIFORM OR RANDOM CASE SIZES
- TOP AND BOTTOM SEALING
- SIDE OR VERTICAL SEALING
- ACCESSORIES



Case sealers for uniform case sizes

T-10 for round-the-clock applications - Top and bottom closure

Very sturdy machine for high requirements. Also available in stainless steel, e.g. for the food industry where machines are required that are easy to clean and maintain in order to meet the increasing demand for hygiene.

Basic models

T-10 and T-10 Maxi (see table). Both models are available with extra high pillars.

T-10 Maxi is especially suitable in industries where large cases are handled. In its standard version, the T-10 Maxi is fitted with a 75 mm dispenser with 70 mm tape overlap.

- Easy to adjust for different case sizes.
- Easy tape and dispenser replacement.
- Strong and compact design.
- Easy to maintain with low maintenance and spare parts costs.
- Electro-galvanised or stainless steel finish.
- Wide range of accessory equipment.



Item numbers

Model	Item no.
T-10 5-5-7	435646713
T-10 5-8-7	435646913
T-10 Maxi 7-5-7	435642133
T-10 Maxi 7-8-7	435642333

All measurements are in mm. Subject to alteration.

Case sealers for uniform case sizes

Specifications	T-10 5-5-7	T-10 5-8-7	T-10 Maxi 7-5-7	T-10 Maxi 7-8-7
Case dimensions*				
Max. (LxWxH) mm	∞ x 515 x 505	∞ x 515 x 815	∞ x 725 x 505	∞ x 725 x 815
Min. (LxWxH) mm	140 x 90 x 80/120**	140 x 90 x 80/120**	140 x 140 x 110/150**	155 x 140 x 110/150**
Tape overlap				
70 mm	●	●	●	●
50 mm	○	○	○	○
Tape width				
25 - 30 mm	○	○	○	○
38 - 50 mm	●	●	○	○
50 - 75 mm	○	○	●	●
Side drives				
Height 50 mm	●	●	○	○
Height 80 mm	○	○	●	●
Working height max./min.				
920 - 820 mm	○	○	○	○
820 - 720 mm	○	○	○	○
720 - 620 mm	●	●	●	●
620 - 520 mm	○	○	○	○
520 - 420 mm	○	○	○	○
Weight kg	165	165	170	170
Capacity*	Max. 30/ min.			
Electric specifications	3 x 230/400 V, 50-60 Hz, or 3 x 415/460 V, 50-60 Hz. Connected load 0.3 kW. Other specifications available upon request.			
Tape diameter	Max. 385 mm.			

● Standard ○ Optional

* Depending on the construction and quality of the case. ** Without or with side pressure rollers.

Subject to alteration.

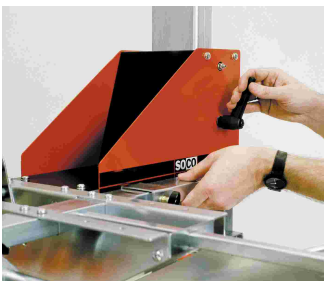

Easy and quick height adjustment.

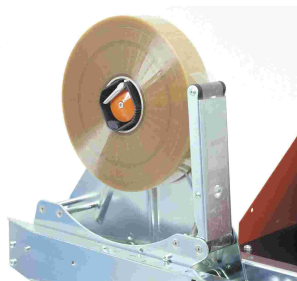

High quality tape dispensers.



Efficient side drives easy to adjust to relevant case size.

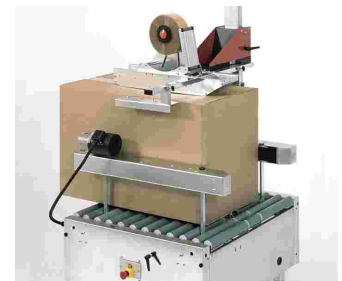

Raised side drives for high cases.

Case sealers for uniform case sizes



Accessories

- ▶ 3-flap folder for T-10 and T-100
- ▶ Tape dispensers - Standard
- ▶ Spare parts kit for dispensers

T-10 with stamp coder

Various coding equipment is available for the T-10 series: side, top and bottom coders.
(Kirk Food A/S)

Machine dimensions

T-10 5-5-7 / 5-8-7

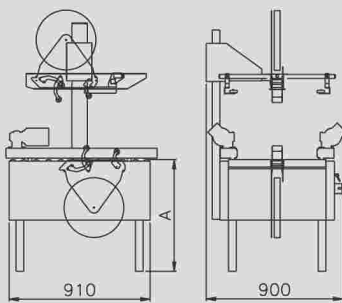

T-10 Maxi 7-5-7 / 7-8-7

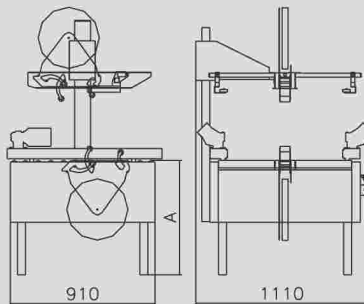

Alle measures are in mm. A = working height. Subject to alteration.

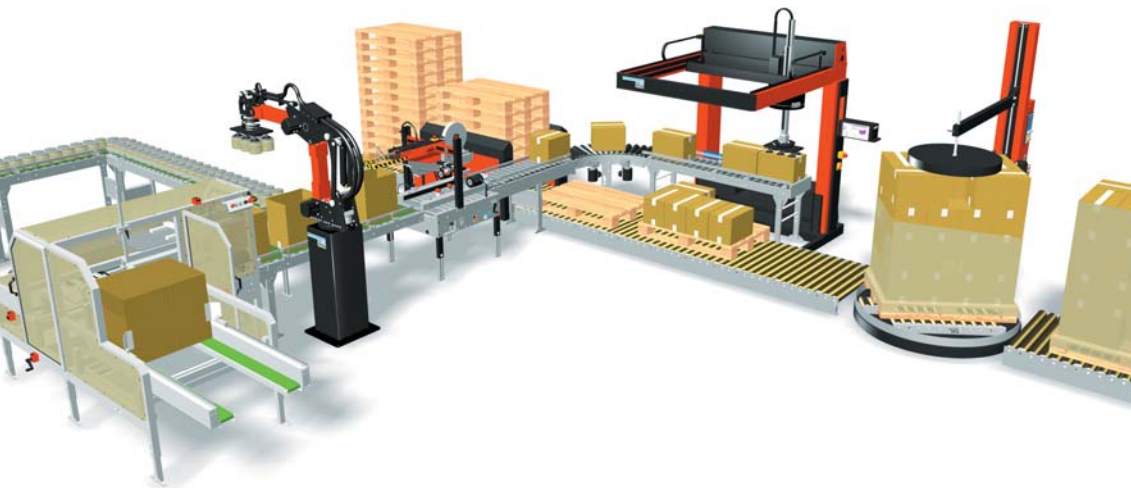

The SOCO SYSTEM

From case erecting to pallet securing

The SOCO SYSTEM product range handles cases, plastic crates, trays, pallets, and many of your products.

The SOCO SYSTEM product range is designed to increase efficiency and eliminate physically strenuous work functions.

One system – one supplier

There are many advantages of full product compatibility; less paperwork and no time wasted in adapting products from different suppliers.

Meet your future requirements

Add modules and functionality, relocate modules, or whatever fits your future needs.

Call us, mail us, or visit us at www.socosystem.com



Your local SOCO SYSTEM dealer:

Arctec (Pty) Ltd.
P.O. Box 70636, Bryanston, 2021

11 Barbeque Terrace
Dytchley Road, Kyalami
Midrand, South Africa

S26° 00' 09.11" E28° 04' 22.18"

COPYRIGHT SOCO SYSTEM 2006



Head office:
SOCO SYSTEM A/S
Helgeshoej Allé 16D
DK-2630 Taastrup
Denmark
Tel +45 43 52 55 66
Fax +45 43 52 81 16
info@socosystem.com
www.socosystem.com



Geberit AG, Switzerland



Sig. Ágústsson, Iceland



Laru, Germany



Toms, Denmark



Rioja, Spain



Bouché Père & Fils, France



United Milk, England



Altmark Käserei, Germany