

SEALING

- SEMI OR FULLY AUTOMATIC
- UNIFORM OR RANDOM CASE SIZES
- TOP AND BOTTOM SEALING
- SIDE OR VERTICAL SEALING
- ACCESSORIES



Case sealers for uniform case sizes

T-2002 with top and bottom drive - top and bottom sealing

The driven top and bottom drives make the machine especially suitable for overfilled cases and high, narrow, or short cases.

The machine is easy to clean and resistant to vapour and moisture.

Basic models

The compact machine is available in two basic models T-2002 and T-2002 Maxi.

- The machine is very easy to adjust for current case size and adjustment can be carried out from both sides.
- Easy change of tape.
- Compact design.
- Easy and economical maintenance.
- Extensive accessory programme, e.g. braked castors, packaging tables, and conveyors.

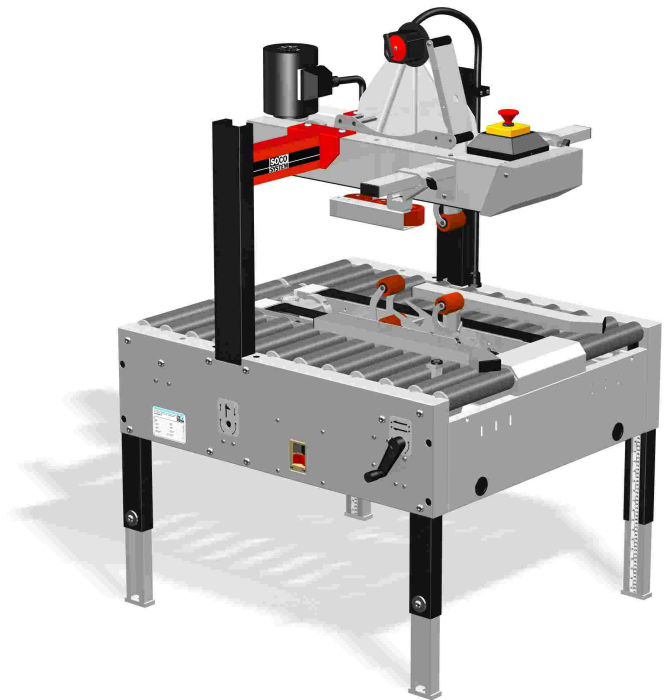

Specifications	T-2002 5-5-9	T-2002 5-8-9	T-2002 Maxi 7-5-9	T-2002 Maxi 7-8-9
Case dimensions*				
Max. (LxWxH) mm	∞ x 500 x 500	∞ x 500 x 800	∞ x 700 x 500	∞ x 700 x 800
Min. (LxWxH) mm	140 x 160 x 170	140 x 160 x 170	140 x 160 x 170	155 x 160 x 170
Tape overlap				
70 mm	●	●	●	●
50 mm	○	○	○	○
Tape width				
25 - 30 mm	○	○	○	○
38 - 50 mm	●	●	●	○
50 - 75 mm	○	○	○	●
Weight kg	165	168	168	175
Capacity*	Max. 30/ min.			
Electric specifications	3 x 230/400 V, 50-60 Hz, or 3 x 415/460 V, 50-60 Hz. Connected load 0.3 kW. Other specifications available upon request.			
Tape diameter	Max. 385 mm.			
● Standard ○ Optional				
* Depending on the construction and quality of the case.				
Subject to alteration.				

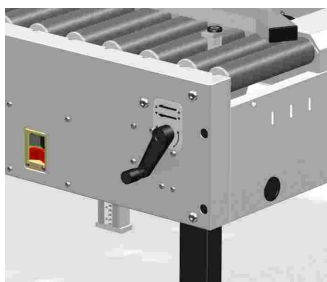

Crank handle adjustment for case size.

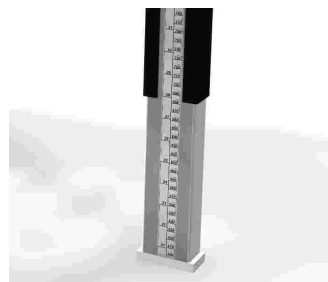

Tape measure on the legs of the machine for easy and precise working height adjustment.

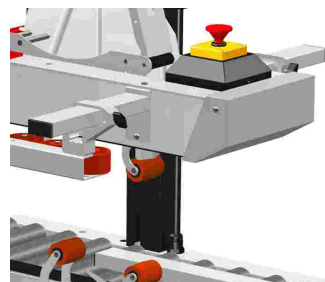

Side pressure guides and centrally placed emergency stop switch.

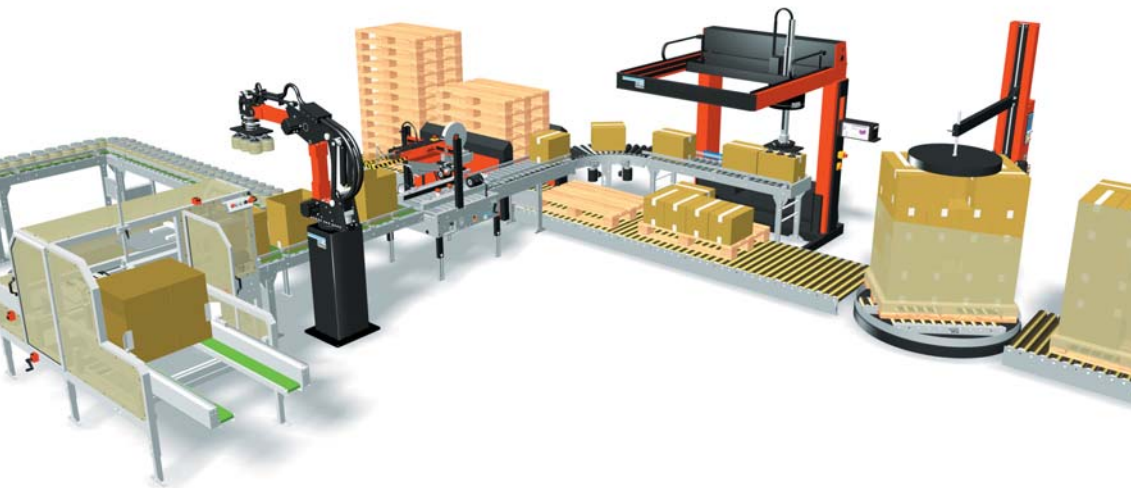

The SOCO SYSTEM

From case erecting to pallet securing

The SOCO SYSTEM product range handles cases, plastic crates, trays, pallets, and many of your products.

The SOCO SYSTEM product range is designed to increase efficiency and eliminate physically strenuous work functions.

One system – one supplier

There are many advantages of full product compatibility; less paperwork and no time wasted in adapting products from different suppliers.

Meet your future requirements

Add modules and functionality, relocate modules, or whatever fits your future needs.

Call us, mail us, or visit us at www.socosystem.com



Your local SOCO SYSTEM dealer:

Arctec (Pty) Ltd.
P.O. Box 70636, Bryanston, 2021

11 Barbeque Terrace
Dytchley Road, Kyalami
Midrand, South Africa

S26° 00' 09.11" E28° 04' 22.18"

COPYRIGHT SOCO SYSTEM 2006



Head office:
SOCO SYSTEM A/S
Helgeshoej Allé 16D
DK-2630 Taastrup
Denmark
Tel +45 43 52 55 66
Fax +45 43 52 81 16
info@socosystem.com
www.socosystem.com



Geberit AG, Switzerland



Sig. Ágústsson, Iceland



Laru, Germany



Toms, Denmark



Rioja, Spain



Bouché Père & Fils, France



United Milk, England



Altmark Käserei, Germany