

# SEALING

- SEMI OR FULLY AUTOMATIC
- UNIFORM OR RANDOM CASE SIZES
- TOP AND BOTTOM SEALING
- SIDE OR VERTICAL SEALING
- ACCESSORIES



# Case sealers for random case sizes

## T-55 Automatic adjustment for case size - Top and bottom closure

The automatic height and width adjustment makes the T-55 ideal in packing lines where case sizes vary, e.g. in the dispatch department of warehouses. Two operators can work simultaneously on either side of the packing table.

The T-55 can operate as a fully automatic top and bottom sealer provided the top flaps of the case are closed by means of a control label or a small piece of tape.

### Basic models

T-55 and T-55 Maxi. Both models are available with high pillars for extra tall cases.

- Easy tape and dispenser replacement.
- Easy to maintain with low maintenance and spare parts costs.
- Wide range of accessory equipment.
- Electro-galvanised or stainless steel finish.

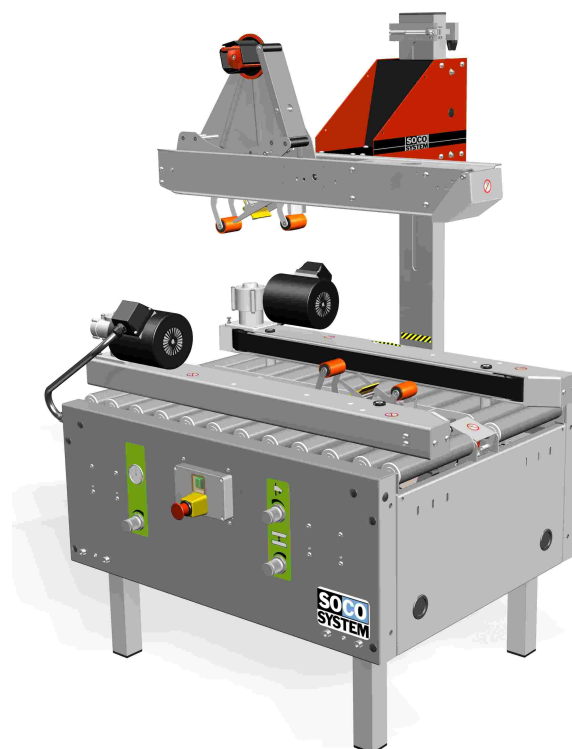

Specifications	T-55 5-5-7	T-55 5-8-7	T-55 Maxi 7-5-7	T-55 Maxi 7-8-7
Case dimensions*				
Max. (LxWxH) mm	∞ x 510 x 510	∞ x 510 x 810	∞ x 720 x 510	∞ x 720 x 810
Min. (LxWxH) mm	160 x 95 x 85	160 x 95 x 220	160 x 150 x 115	160 x 150 x 220
Tape overlap				
70 mm	●	●	●	●
50 mm	○	○	○	○
Tape width				
25 - 30 mm	○	○	○	○
38 - 50 mm	●	●	○	○
50 - 75 mm	○	○	●	●
Side drives				
Height 50 mm	●	●	○	○
Height 80 mm	○	○	●	●
Working height max./min.				
920 - 820 mm	○	○	○	○
820 - 720 mm	○	○	○	○
720 - 620 mm	●	●	●	●
620 - 520 mm	○	○	○	○
520 - 420 mm	○	○	●	○
Weight kg	175	165	170	170
Capacity*	Max. 16 cases/ min.			
Electric specifications	3 x 230/400 V, 50-60 Hz, or 3 x 415/460 V, 50-60 Hz. Connected load 0.3 kW. Other specifications available upon request.			
Air consumption	Max. 8.5 l at 6 bar per case.			
Tape diameter	Max. 385 mm.			
● Standard ○ Optional				
*Depending on the construction and quality of the case.				
Subject to alteration.				

# Case sealers for random case sizes

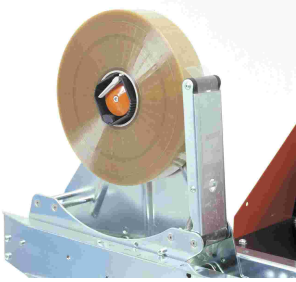

High quality tape dispensers.

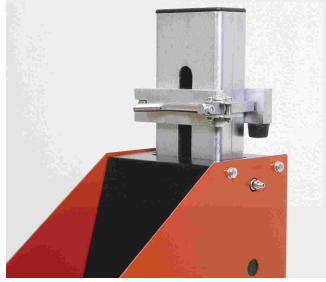

Pillar stop for maximum efficiency.



The model T-55 is for packing stations that handle many different sizes of case.

## Machine dimensions

T-55 5-5-7 / 5-8-7

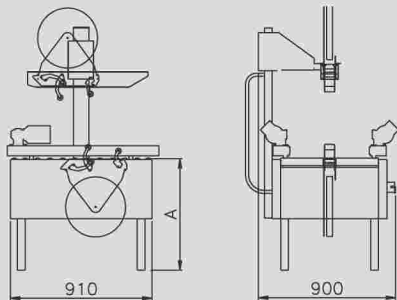

T-55 Maxi 7-5-7 / 7-8-7

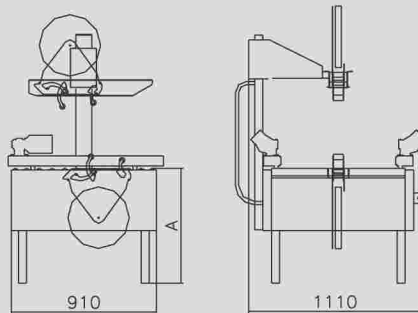

Alle measures are in mm. A = working height. Subject to alteration.

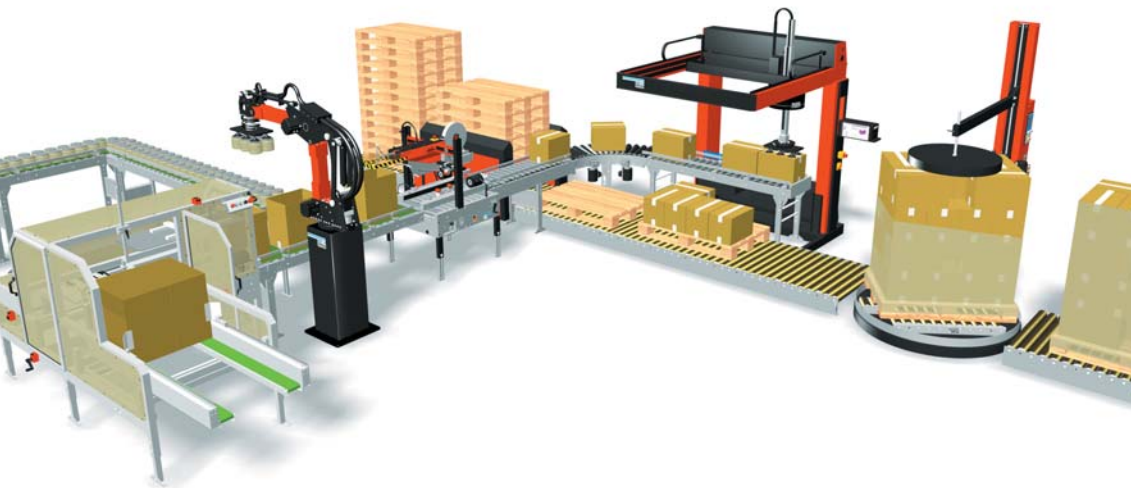

## The SOCO SYSTEM

### From case erecting to pallet securing

The SOCO SYSTEM product range handles cases, plastic crates, trays, pallets, and many of your products.

The SOCO SYSTEM product range is designed to increase efficiency and eliminate physically strenuous work functions.

#### One system – one supplier

There are many advantages of full product compatibility; less paperwork and no time wasted in adapting products from different suppliers.

#### Meet your future requirements

Add modules and functionality, relocate modules, or whatever fits your future needs.

Call us, mail us, or visit us at [www.socosystem.com](http://www.socosystem.com)



Your local SOCO SYSTEM dealer:

Arctec (Pty) Ltd.  
P.O. Box 70636, Bryanston, 2021

11 Barbeque Terrace  
Dytchley Road, Kyalami  
Midrand, South Africa

S26° 00' 09.11" E28° 04' 22.18"

COPYRIGHT SOCO SYSTEM 2006



Head office:  
**SOCO SYSTEM A/S**  
Helgeshoej Allé 16D  
DK-2630 Taastrup  
Denmark  
Tel +45 43 52 55 66  
Fax +45 43 52 81 16  
[info@socosystem.com](mailto:info@socosystem.com)  
[www.socosystem.com](http://www.socosystem.com)



Geberit AG, Switzerland



Sig. Ágústsson, Iceland



Laru, Germany



Toms, Denmark



Rioja, Spain



Bouché Père & Fils, France



United Milk, England



Altmark Käserei, Germany