

PALLET HANDLING

- ROLLER CONVEYORS
- CHAIN CONVEYORS
- ROTARY TABLES
- TRANSFER UNITS
- TRANSFER TROLLEYS
- PALLET MAGAZINES
- ACCESSORIES
- CONTROL SYSTEMS

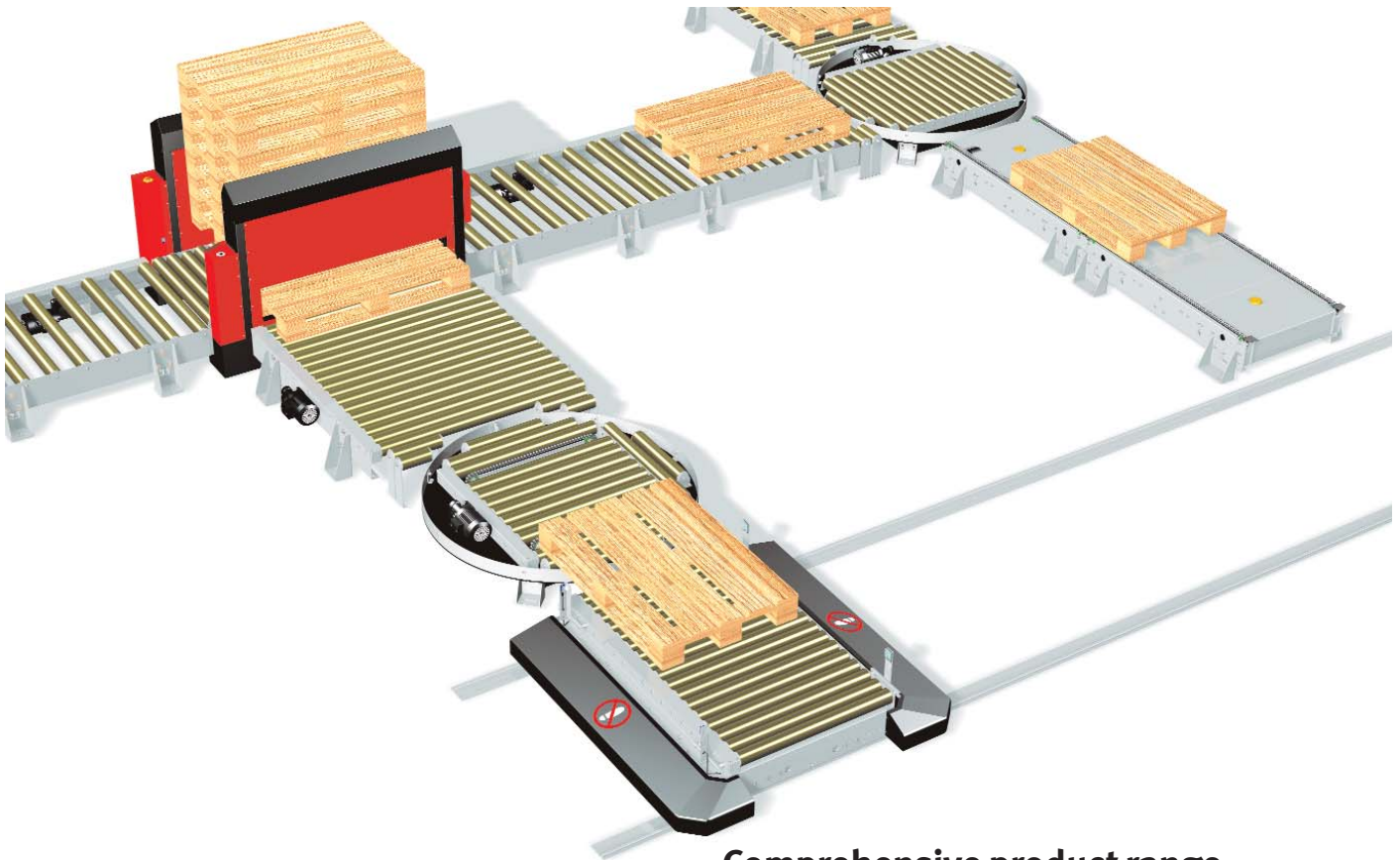

We move your pallets



Comprehensive product range

SOCO SYSTEM's pallet handling programme is very extensive. Comprising a multitude of standard components, the system can be combined into an infinite number of functional modules that can be combined endlessly.

The system is easy to install, re-locate, adapt, maintain, and extend.

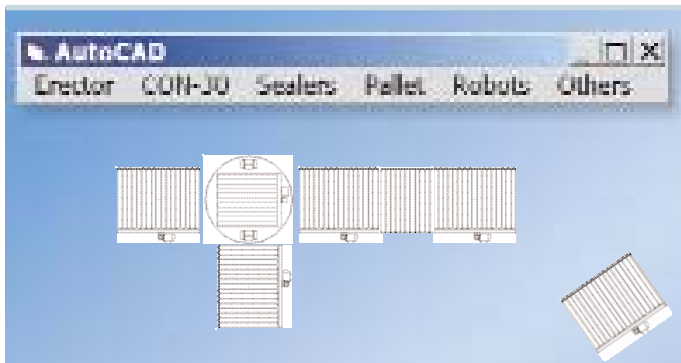

Design your own plant layout with SOCO SYSTEM Manager

Design your own packaging station, packing and conveying line on your own computer using the complete range of SOCO SYSTEM modules. All modules are available in a variety of widths and lengths.

The SOCO SYSTEM Manager is a supplementary programme to AutoCAD and AutoCAD LT. Once installed, the SOCO SYSTEM Manager is part of the menu for both programmes.



Service and spare parts

SOCO SYSTEM's products are highly reliable and require only minimum maintenance.

All standard equipment is supplied with a spare parts manual. This manual makes ordering of spare parts quick and simple. Spare parts are available from stock and can be supplied with short notice.

A team of highly motivated and efficient SOCO SYSTEM employees are available for your service and assistance.

How to choose the right equipment

Which pallet types do you use?

Pallet size, configuration, construction, and weight decide the conveyor type.

Standard EUR pallets 800 mm x 1200 mm,

1000 mm x 1200 mm and 1200 mm x 1200 mm

can be moved **longways** i.e. with the 800 mm, 1000 mm or 1200 mm side leading – on standard pallet roller conveyors with roller pitch 178 mm.

can be moved **crossways** i.e. with the 1200 mm side leading – on pallet roller conveyors with narrow roller pitch, i.e. pitch 89 mm.

400 mm x 600 mm pallets – so-called 1/4 pallets,

and 600 mm x 800 mm pallets – so-called 1/2 pallets

can usually be moved on pallet conveyors with narrow roller pitch 89 mm, however there are bottom configurations that do not allow this – please consult SOCO SYSTEM for advice and further details.

48" x 42" and 48" x 48" – GMA type pallets

can, in most cases, be moved with 48" side leading on conveyors with roller pitch 178 mm and with either side leading on conveyors with narrow roller pitch, i.e. 89 mm.

Full base pallets

i.e. pallets with bottom boards in all 4 directions can easily be moved with either side leading on conveyors with roller pitch 178 mm.



Chain or roller conveyor?

Chain conveyors are used where the bottom configuration of the pallets does not allow it to be moved on pallet roller conveyors.

Chain conveyors are often more suitable for 1/4 pallets.

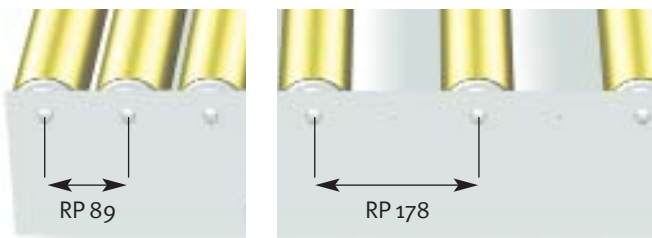

Which roller pitch to use?

Roller pitch – RP – is the distance between the roller centres.

RP 178 mm with roller diameter 80 mm is the most economical in terms of conveyor price, however, in most cases, this requires fencing to meet industry requirements and regulations for personnel safety and security.

RP 89 mm does not require fencing, and most pallet configurations can be conveyed with either side leading.



Driven or non driven?

SOCO SYSTEM does not recommend handling of loaded pallets on non-driven conveyors. The reason is that loads can easily become dislocated on the pallets, products can slide and fall off the pallets, causing product damage and personnel hazards.

The pallet handling system

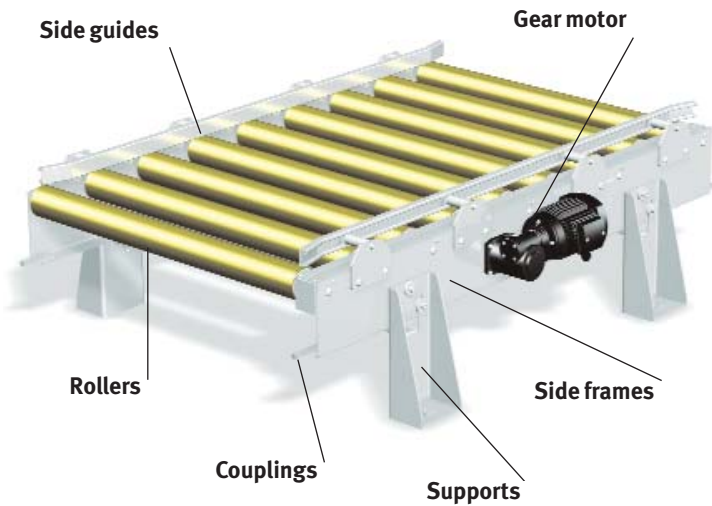

A world of possibilities

Imagination is the only limitation to the number of possible applications of the pallet handling system.

To give an idea of the construction principles and the possibilities, the various components of a driven roller pallet conveyor are explained.

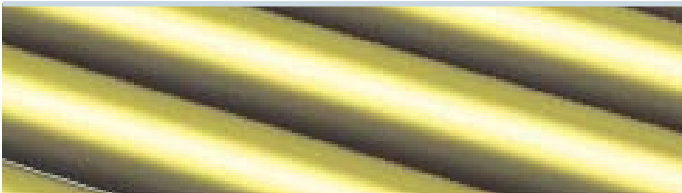

Rollers

SOCO SYSTEM's rollers and chains have excellent wear and tear properties, and they are smooth-running components made from the best raw materials. Standard diameter is \varnothing 80 mm.



Side guides

Side guides are available for mounting in different heights. The side guides aid the pallets to maintain the correct direction.



Side frames

The frames form the main structure of the conveyor and are designed for both function and harmony.

Frames come in different heights: 90 mm for mounting direct on the floor and 190 mm for additional heights.



Gear motor

The sturdy and reliable standard gear motor is a 0.37 kW motor with a speed of 11.4 m/min. Other speeds are available on request.

The hollow shaft worm reduction gear is bolted to the conveyor frame.



Supports

Are available for inside or outside mounting, for stationary attachment to floor, or to stand direct on the floor.

Supports are available in various heights.

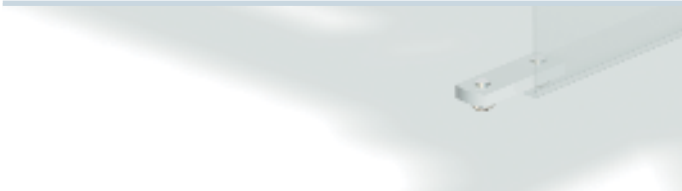

Couplings

A variety of standard fittings makes it easy to connect the modules.

All couplings are easily and quickly mounted.

Transfer trolleys

Suitable for transport of pallets between two or more conveyor lines.

Several possible applications include delivering empty pallets from a pallet magazine to several pallet loaders and collecting full pallets and transferring these for onward central conveyance.

The transfer trolley can be fitted with:

- Driven roller conveyors.
- Chain conveyors.

The standard transfer trolley has safety bumpers. On contact, the transfer trolley stops. The transfer trolley runs on rails fitted into or on the floor.

Together with an order inquiry, please provide the following additional information to SOCO SYSTEM:

- Products to be transferred.
- Pallet sizes and direction of movement.
- Pallet load height.
- Required operating height - minimum and standard is 350 mm.
- Distance of trolley movement.
- Required capacity as number of pallet transfers per hour.
- Preferred method of power supply through "overhead rail" or floor mounted "power chain".
- Preferred type of floor rail - "built-in" or "rails-on-floor".
- Preferred method of personnel protection.

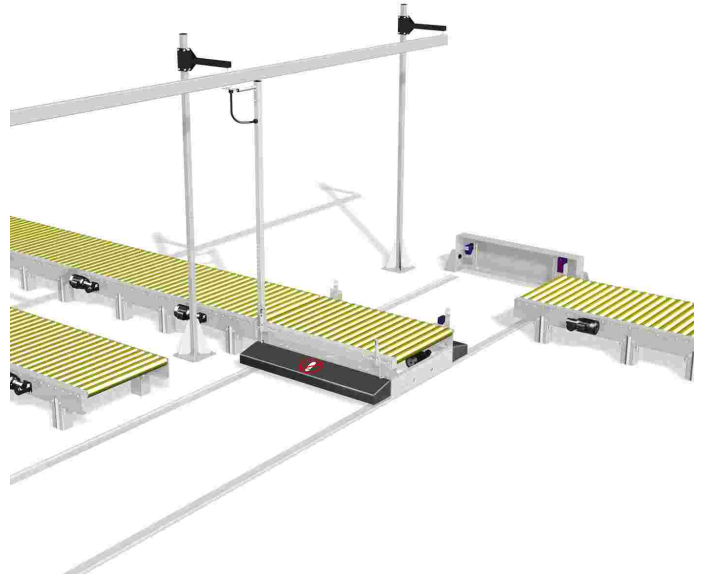
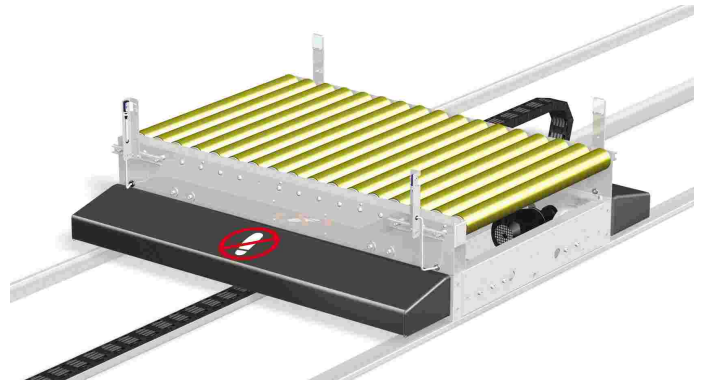

Specifications

Payload	Max. 1500 kg.
Standard width	970 mm, 1170 mm, and 1370 mm.
Standard length	1500 mm.
Gear motor	2 units each of 0.25 kW.
Speed	Standard 10 m/min. Other speeds available on request.
Operating height	With roller conveyor: Minimum 350 mm. With chain conveyor: Minimum 450 mm. Other heights on request.
Subject to alteration.	



Transfer trolley installed in a pallet roller conveyor system supplied to Organon, Ireland.

Control systems

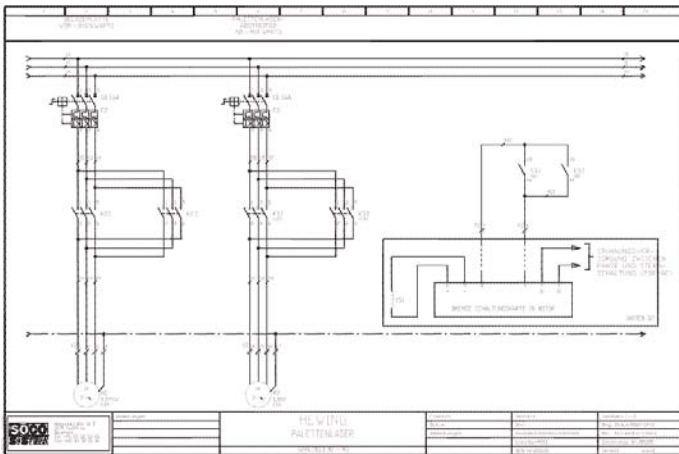

Clear electrical diagrams detail the programme setup.

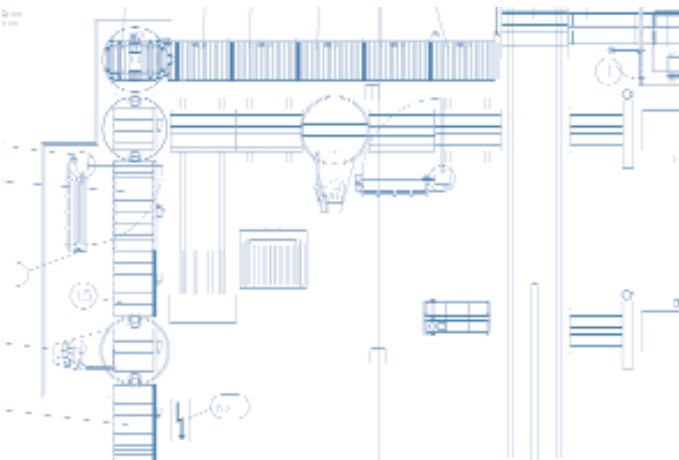

Full system layout is provided with each installation.

Control systems

SOCO SYSTEM supplies customised control systems for end-of-line packing and handling systems.

Our control systems are based on PLC programme platforms such as Siemens, Omron, Allen – Bradley. Customer specifications and customer choice of control systems and electrical components can be met.

Palletising equipment

Systems including palletising robots are supplied as standard with an IPC equipped with a Soft-PLC. This supports in full the IEC 1131 standard.

Overall operating system platform and man/machine interface is Windows based.

The IPC controlling the palletising robot can also control virtually all peripheral equipment. Production data can be provided for overall control systems. Programmes can be changed through modem access, and error messages can be sent by e-mail or SMS.

Operator interface

SOCO SYSTEM's user interfaces are designed to facilitate the operation of the system, with well-defined error messages to ensure simple trouble-shooting procedures.

It can be designed for different levels of access to ensure maximum machine security and personnel safety.

Operator interface systems are a very important feature in the smooth operation of integrated end-of-line systems. SOCO SYSTEM has proven experience in developing efficient operator interfaces.

Contact our project department for further information

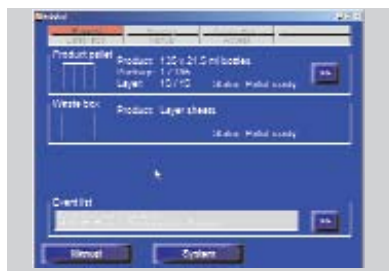

Customised control panels with touch screen features for easy man/machine interaction.

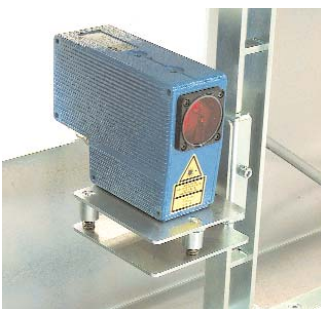

Photocell monitoring.



Well organised control cabinets with space for expansion.

Safety guidelines

SOCO SYSTEM modules are manufactured to meet CE requirements and specifications.

Each module is secured individually in the best possible way. Combinations of modules, however, may require further safety and security measures to prevent accidents and to increase personnel safety.

SOCO SYSTEM offers an individual safety and personnel security evaluation as well as recommend solution. Such solutions can include fencing, light curtains, automatic gates, safety curtains, and doors operated and controlled automatically. This ensures that the complete installation meets the requirements in the EEC directives.

The solutions offered are tailor-made to meet your specific requirements and to suit your premises.

SOCO SYSTEM integrates the most recent industrial security systems from reputable European suppliers.

SOCO SYSTEM equipment meets the following EC directives:

73/23 EEC – 89/336 EEC
– 98/37 EC

and thereby also the following harmonised standards:

EN 291-X – EN 418 – EN 954
– EN 959 – EN 999 – EN 1050 –
EN 60204-1.



Customised fencing for pallet conveyor line with integrated fully automatic pallet stretch wrapper.



Automatic light curtain protection preventing entry to the danger zone but allowing exit of a full pallet.

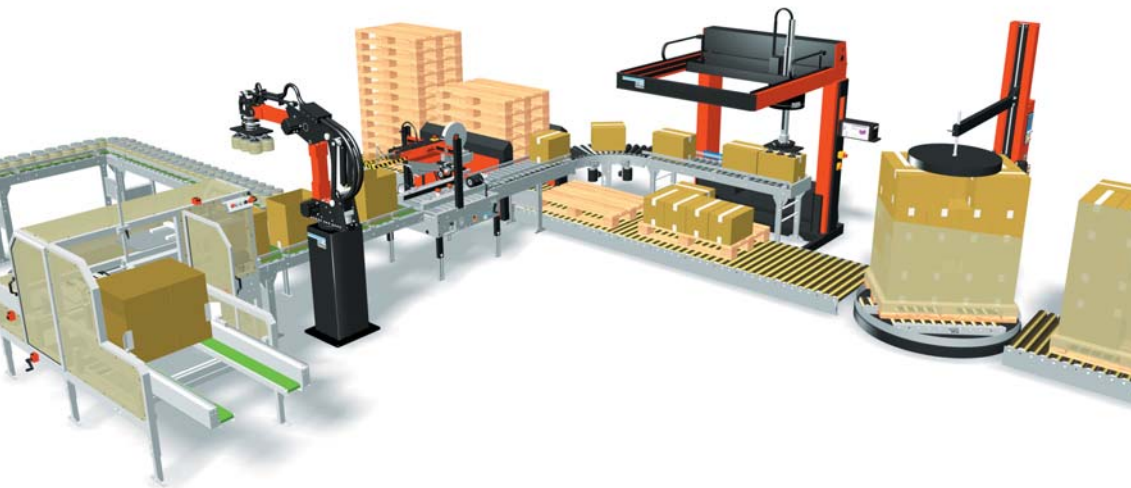

The SOCO SYSTEM

From case erecting to pallet securing

The SOCO SYSTEM product range handles cases, plastic crates, trays, pallets, and many of your products.

The SOCO SYSTEM product range is designed to increase efficiency and eliminate physically strenuous work functions.

One system – one supplier

There are many advantages of full product compatibility; less paperwork and no time wasted in adapting products from different suppliers.

Meet your future requirements

Add modules and functionality, relocate modules, or whatever fits your future needs.

Call us, mail us, or visit us at www.socosystem.com



Your local SOCO SYSTEM dealer:

Arctec (Pty) Ltd.
P.O. Box 70636, Bryanston, 2021

11 Barbeque Terrace
Dytchley Road, Kyalami
Midrand, South Africa

S26° 00' 09.11" E28° 04' 22.18"

COPYRIGHT SOCO SYSTEM 2006



Head office:
SOCO SYSTEM A/S
Helgeshoej Allé 16D
DK-2630 Taastrup
Denmark
Tel +45 43 52 55 66
Fax +45 43 52 81 16
info@socosystem.com
www.socosystem.com



Geberit AG, Switzerland



Sig. Ágústsson, Iceland



Laru, Germany



Toms, Denmark



Rioja, Spain



Bouché Père & Fils, France



United Milk, England



Altmark Käserei, Germany